

REVISION HISTORY						
ZONE	REV	DESCRIPTION	DATE	APPROVED	DRAWN	ISSUED
-	1.0	RELEASED	-	-	-	-

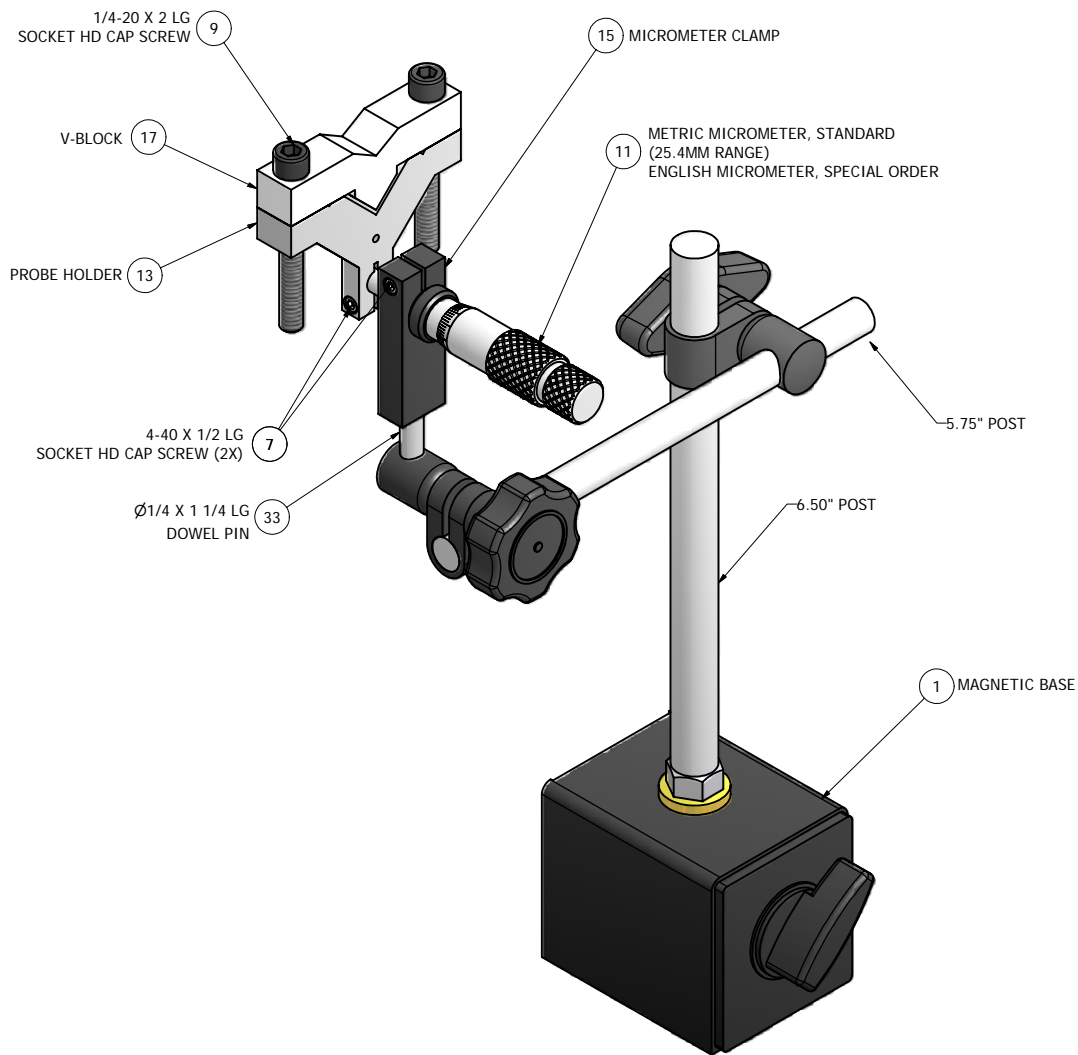

UNLESS OTHERWISE SPECIFIED DIM ARE IN INCHES TOL ON ANGLE $\pm .5^\circ$ 2 PL $\pm .01$ 3 PL $\pm .005$ INTERPRET DIM AND TOL PER ASME Y14.5M-1994		DRAWN BVA	12/3/2009	mti instruments			
THIRD ANGLE PROJECTION		CHECKED				ASSEMBLY, FS-2 PROBE POSITION FIXTURE	
		DESIGN		SIZE	FSCM NO		
		ISSUED BVA		C	26741	8000-4186CS	1.0
		APPROVED		SCALE		SHEET 1 OF 1	
		<small>PROPRIETARY INFORMATION NOTICE THE INFORMATION CONTAINED IN THIS DOCUMENT IS DISCLOSED IN CONFIDENCE. IT IS THE PROPERTY OF MTI INSTRUMENTS INC. AND SHALL NOT BE DISCLOSED TO OTHERS OR REPRODUCED WITHOUT THE EXPRESS WRITTEN CONSENT OF MTI INSTRUMENTS INC.</small>					