

REVISION HISTORY						
ZONE	REV	DESCRIPTION	DATE	APPROVED	DRAWN	ISSUED
-	1.0	RELEASED	-	-	-	-

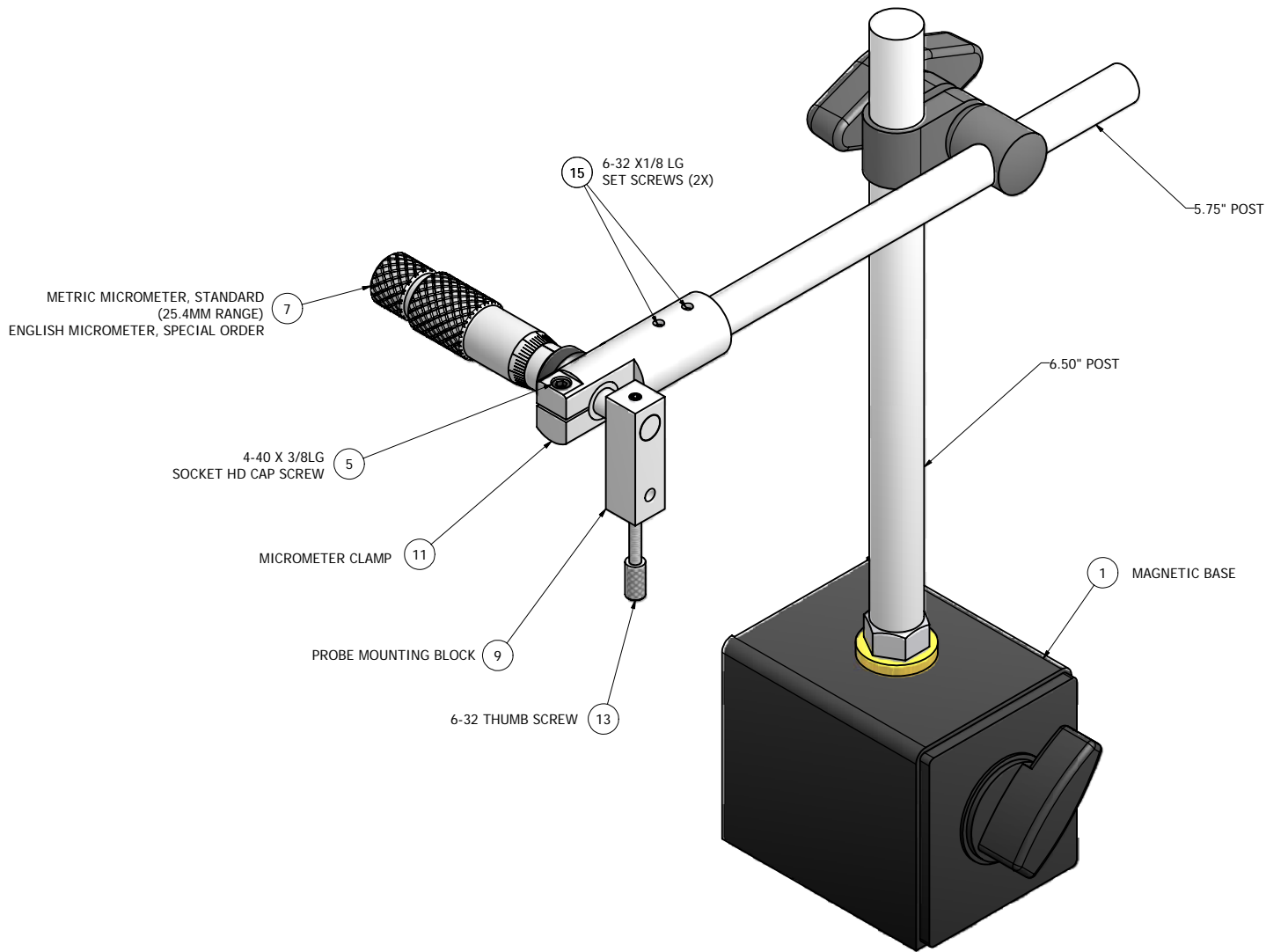

UNLESS OTHERWISE SPECIFIED DIM ARE IN INCHES TOL ON ANGLE $\pm .5^\circ$ 2 PL $\pm .01$ 3 PL $\pm .005$ INTERPRET DIM AND TOL PER ASME Y14.5M-1994 THIRD ANGLE PROJECTION	DRAWN	BVA 18NOV09	11/18/2009
	CHECKED		
	DESIGN		
	ISSUED	BVA	
	APPROVED		
PROPRIETARY INFORMATION NOTICE THE INFORMATION CONTAINED IN THIS DOCUMENT IS DISCLOSED IN CONFIDENCE. IT IS THE PROPERTY OF MTI INSTRUMENTS INC. AND SHALL NOT BE DISCLOSED TO OTHERS OR REPRODUCED WITHOUT THE EXPRESS WRITTEN CONSENT OF MTI INSTRUMENTS INC.			



ASSEMBLY, FS-3  
 PROBE POSITION FIXTURE

SIZE	FSCM NO	DWG NO	REV
C	26741	8000-4204CS	1.0
SCALE			SHEET 1 OF 1