

MICROTRAK™ 7000



*The Most Advanced Laser
Displacement Sensor In Its Class*

MICROTRAK 7000

*Built on a 30-year commitment
to noncontact sensing technology*



*Measures distance, displacement, vibration or thickness
without contact - at operating distances of up to 6.0 in. (15.2 cm)*

The most advanced laser-based triangulation measurement system in its class, the MICROTRAK 7000 provides high resolution and wide-range frequency response in one, ruggedly built instrument. Whether on the production floor or in the laboratory, the new MICROTRAK 7000 gives you:

- A wide range of innovative features and performance advantages
- Simple setup, easy operation and application versatility
- Superior product quality and total commitment to customer satisfaction

The MICROTRAK 7000 is the latest addition to the MTI Instruments line of high-precision, noncontact measurement systems. The MICROTRAK 7000 offers an effective and affordable solution for quality and process control.

System Features and Advantages

- **Unmatched Resolution** is achieved through high-quality optics, latest microchip technology and advanced digital signal processing.
- **High Sampling Rate** (100 kHz) and 20 kHz frequency response ensure accurate, real-time data, even for high-speed on-line gaging.
- **Fluorescent LCD Alphanumeric Display** shows convenient setup parameters and control functions.
- **Menu-Driven Controller** provides easy selection of limit checking, gain, averaging, mode selection, inch/mm and other features.
- **Two Laser Heads with a Single Controller** simplify thickness and warpage measurements.
- **Visible Laser Beam** allows easy positioning and aligning of sensing heads.
- **Rear Panel Terminals** permit interconnection of remote high/low alarm., zero and hold, etc.
- **Unique Algorithm** prevents crosstalk between laser heads, even with transparent targets.
- **RS-232c, IEEE-488 and Analog Output** available.
- **Customized OEM Designs** for dedicated user applications.



Change Laser Heads-No Recalibration!

Each MICROTRAK 7000 laser sensing head contains its own microcircuitry. Simply plug it in, and it communicates directly to the signal processor for automatic setup.

Unlike other systems, which require recalibration by the manufacturer when changing heads, the MICROTRAK 7000 allows the user to change laser heads without recalibration. This versatility makes the MICROTRAK 7000 a cost-effective solution for laboratory or factory environments.

Application solutions for Quality and Process Control ...

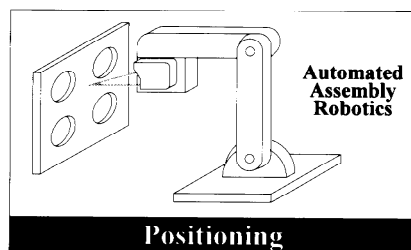
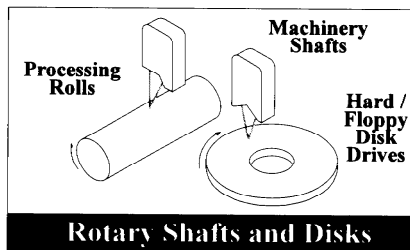
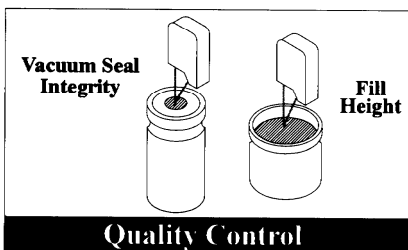
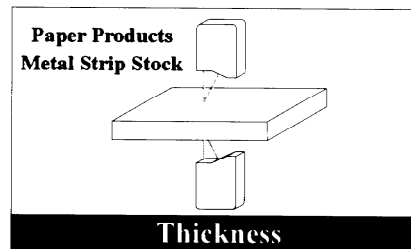
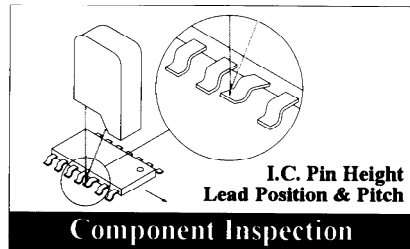
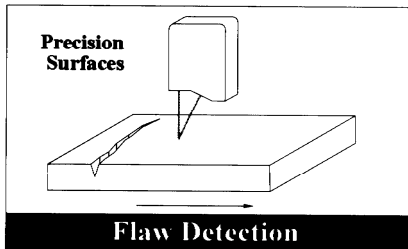
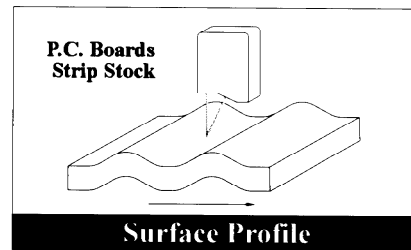
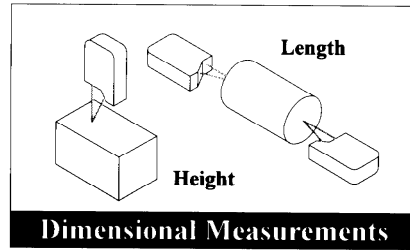
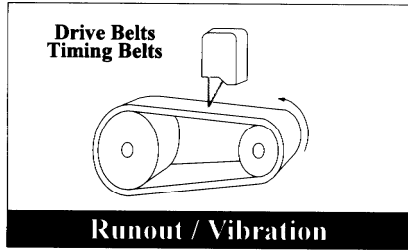

... Meeting the exacting requirements of our customers worldwide.

AUTOMOTIVE/MACHINERY

Manufacturing

- Stamping • Punch Press
- Welding • Painting • Thickness Control
- Engine (connecting rod, machining, thread detection) • Tire (runout, sidewall inspection, tire rim testing)

Development

- Valve Train Dynamics
- Accessory Mounting Vibrations
- Drive Belt Vibrations
- Cooling Fan Runout
- HVAC Blower Runout
- Suspension Dynamics

ELECTRONICS/SEMICONDUCTORS

PC Board

- Thickness • Stack Height
- Warpage • Alignment

Components

- Presence • Placement Orientation
- Alignment • Height
- Lead Location • Insulation

FOOD&BEVERAGE

Manufacturing

- Fill Height • Vacuum Seal Integrity

PHARMACEUTICALS

Production

- Tablet Height

Automation

- Robotic Positioning

COMPUTERS/PERIPHERALS

Hard Disk Drive

- Monitor and Control of Automated Assembly Machines, e.g., Positioners and Robotic Arms

VCR/Digital Audio Tape

- Assembly Alignment
- Load/Unload Mechanism Operations

PULP&PAPER

Printing

- Missing Sheet Detection • Double Layers
- Roller Height • Gap • Runout

Manufacturing

- Board Thickness • Placement
- Height • Alignment
- Control of Automation Process

Two Standard Controller Models

7000-SL: Single laser head controller • 7000-DL: Dual laser head controller

Seven Standard Laser Head Models

MODEL	STANDOFF	RANGE	RESOLUTION	SPOT SIZE***	HEAD TYPE*
MT-100-5	1.0 in. (25.4 mm)	0.005 in. (0.127 mm)	0.1 μ in. (0.0025 μ m)	0.0012 x 0.0036 in. (30 x 90 μ m)	Specular
MT-100-20	1.0 in. (25.4 mm)	0.02 in. (0.51 mm)	0.5 μ in. (0.0127 μ m)	0.0012 x 0.0036 in. (30 x 90 μ m)	Specular
MT-250-200	2.5 in. (63.5 mm)	0.20 in. (5.1 mm)	5.0 μ in. (0.127 μ m)	0.0024 x 0.0072 in. (60 x 180 μ m)	Diffuse
MT-250-400	2.5 in. (63.5 mm)	0.40 in. (10.2 mm)	10.0 μ in. (0.254 μ m)	0.0024 x 0.0072 in. (60 x 180 μ m)	Diffuse
MT-600-800	6.0 in. (152.4 mm)	0.80 in. (20.3 mm)	50.0 μ in. (1.27 μ m)	0.006x0.010 in. (150 x 250 μ m)	Diffuse
MT-600-1600	6.0 in. (152.4 mm)	1.60 in. (40.6 mm)	100.0 μ in. (2.54 μ m)	0.006 x 0.010 in. (150 x 250 μ m)	Diffuse
MT-600-3000	6.0 in. (152.4 mm)	3.0 in. (76.2 mm)	200 μ in. (5.08 μ m)	0.006 x 0.010 in. (150 x 250 μ m)	Diffuse

*Diffuse sensors can be used for most surfaces. Highly reflective, mirrored surfaces require a specular sensor.
 ** Note: For specialized applications, larger spot sizes are available, consult factory.

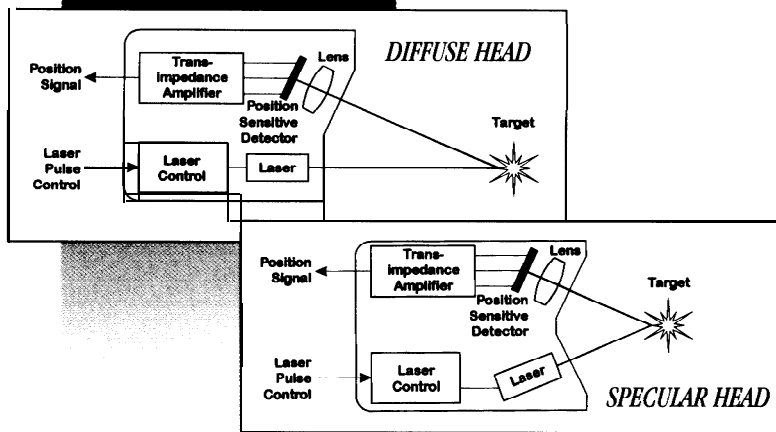

More reasons for choosing the MICROTRAK 7000

- Factory-Based Applications Engineering
- Unparalleled Customer Support
- Toll Free Hot Line:
1-800-342-2203

Operating Principle

Each sensing head contains a solid-state laser light source and a position sensitive detector (psd). When the laser beam is focused on the target surface, the beam is reflected back to the psd, which determines the precise distance to the target, based on the position of the reflected beam. This measurement is converted to engineering units displayed on the MICROTRAK 7000 screen.

A single sensing head can be used to measure displacement, runout or vibration. When sensors are connected to the system's two channels, the MICROTRAK 7000 can calculate thickness or perform sum or difference measurements. In many cases, when a reference is available, only one head is needed for thickness sensing.

Specifications

	MT-100-5 Specular Sensor Head	MT-250-200 Diffuse Sensor Head	MT-600-800 Diffuse Sensor Head
Resolution	0.1 μ m. (0.0025 μ m)	5.0 μ m. (0.127 μ m)	50.0 μ m. (1.27 μ m)
Standoff	1.0 in. (25.4 mm)	2.5 in. (63.5 mm)	6.0 in. (152.4 mm)
Measuring range	0.005 in. (0.127 mm)	0.20 in. (5.1 mm)	0.80 in. (20.3 mm)
Linearity	\pm 0.1% of range	\pm 0.1% of range	\pm 0.1% of range
Accuracy	\pm 0.1% of range		
Dynamic range	96 dB		
Reflectance range	100:1		
Sampling frequency	100 kHz		
Frequency response	20 kHz		
Frequency response with no crosstalk	single Head	Dual Head	
	N/A	2.6 kHz	
Averaging	Low Pass Selectable Filter From 0.03 Hz to 20 kHz		
Response time	95 μ s		
Zero set	Equal to range of the head		
Offset range	\pm 99.999 of units selected		
Temperature stability	.03% FSR/ $^{\circ}$ F(.06% FSR/ $^{\circ}$ C)		
Laser type	Semiconductor, visible red (Class II) 1 mW nominal, 3 mW max. (Class IIIb available)		
Laser wavelength	670 nm		
Ambient illumination	3500 lux maximum		
Analog output	-10V to +10 VDC		
Digital output	Open collector, HV protected 100 mA maximum current sinking		
Digital input	Optically isolated, dry contact to ground activated		
Data interfaces	RS-232C; 300-19,200 baud (selectable) IEEE-488:Externally controlled; 16 Bit parallel Digital Output		
Remote inputs	Remote zero input, Remote hold input Remote laser interlock		
Laser activation	Remotely connecting rear activation terminal to ground activates laser		
External alarm output	High limit, Low limit, Bright or dark limit exceeded Linear range exceeded		
Power	90-260 VAC, autoswitching, 47-63 Hz, 50 W max.		
Weight	Controller: 8.8 lb (4.0 kg) Head: 0.33 lb (0.15 kg)		
Size	Controller: 12.0 in. (304.8 mm) W x 4.5 in. (114.3 mm) H x 10.0 in. (254 mm) D Head: 2.2 in. (55.9 mm) W x 1.0 in. (25.4 mm) H x 3.0 in. (76.2 mm) D 32 $^{\circ}$ F - 125 $^{\circ}$ F (0 $^{\circ}$ C - 50 $^{\circ}$ C)		
Environmental	30% -90% RH, noncondensing		

Laser Beam Safety- Avoid looking directly at the operating laser or looking at the beam reflected from a mirror like surface.

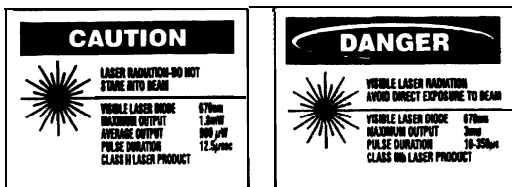

Dimensions (MT-250 Head)

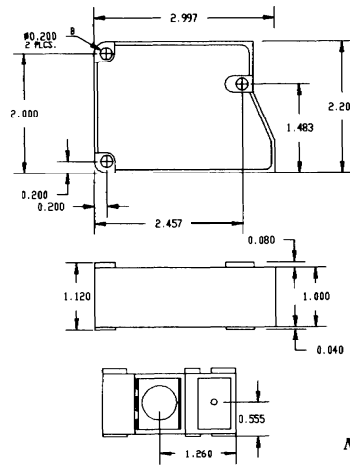

NOTE: All dimensions are in inches.

MTI Instruments: Pioneers in Noncontact Measurement

MTI Instruments has been at the forefront of high-precision, noncontact measurement for more than 30 years. We offer fiber-optic, capacitive, and laser technologies designed to measure position, displacement, and vibration in the production process and in the laboratory.

MTI specializes in providing in-depth technical support before, during and after the sale. Our staff of application engineers and our worldwide network of factory-trained representatives are ready to answer your questions and solve your measurement needs.

call toll-free **1-800-342-2203** for literature on all of MTI's noncontact products:

Additional Sensing Products

- **Accumeasure™ 5000**- high-frequency (20 kHz) single- or dual-channel capacitive system
- **AS-5000-SRT** - computerized runout test system
- **MTI-2000 Fotonic™ Sensor** - fiber-optic based system with high-frequency response (200 kHz)
- **Fotonic Edge™** - fiber-optic module for edge sensing
- **Accumeasure 1500** - multi-channel capacitive gaging system



325 Washington Avenue Extension | Albany, NY 12205
Phone: 518/218-2550. FAX: 518/218-2506

Confidently Innovative

